

Preparation

**Part Number: PTR02-30090**

**Kit Contents:**

Item #	Quantity Reqd.	Description
1	1	Front Sway Bar
2	1	Rear Sway Bar
3	1	Hardware Bag

**Hardware Bag Contents**

Item #	Quantity Reqd.	Description
1	2	Front Bushings
2	2	Rear Bushings
3	4	Bolts M8 x 1.25 / 20mm
4	2	Rear Sway Bar Straps

**Additional Items Required For Installation**

Item #	Quantity Reqd.	Description
1		
2		
3		

**Conflicts**

GS 350 AWD / GS 350 equipped w/Active Stabilizer Control
--

**Recommended Tools**

<b>Personal &amp; Vehicle Protection</b>	<b>Notes</b>
<b>Special Tools</b>	<b>Notes</b>
<b>Installation Tools</b>	<b>Notes</b>
<b>Special Chemicals</b>	<b>Notes</b>

**General Applicability**

GS 350
--------





**Recommended Sequence of Application**

Item #	Accessory
1	
2	

**Vehicle Service Parts** (may be required for reassembly)

Item #	Quantity Reqd.	Description
1	4	Rear Sway Bar Bolts 90119-A0169
2	2	Rear Sway Bar Brackets 48832-30060
3		

**Legend**

	<b>STOP:</b> Damage to the vehicle may occur. Do not proceed until process has been complied with.
	<b>OPERATOR SAFETY:</b> Use caution to avoid risk of injury.
	<b>CAUTION:</b> A process that must be carefully observed in order to reduce the risk of damage to the accessory/vehicle and to ensure a quality installation.
	<b>TOOLS &amp; EQUIPMENT:</b> Used in Figures calls out the specific tools and equipment recommended for this process.
	<b>REVISION MARK:</b> This mark highlights a change in installation with respect to previous issue.

Care must be taken when installing this accessory to ensure damage does not occur to the vehicle. The installation of this accessory should follow approved guidelines to ensure a quality installation

These guidelines can be found in the "Accessory Installation Practices" document.

This document covers such items as:

- Vehicle Protection (use of covers and blankets, cleaning chemicals, etc.).
- Safety (eye protection, rechecking torque procedure, etc.).
- Vehicle Disassembly/Reassembly (panel removal, part storage, etc.).
- Electrical Component Disassembly/Reassembly (battery disconnection, connector removal, etc.).

## 1. Remove Front Sway Bar.

(a) Remove engine under cover.

(b) Remove rear engine under cover LH & RH side. (Fig 1-1)

(1) Clips holding side covers can be released using a special trim clip tool.

(c) Disconnect sway bar link from sway bar. (Fig 1-2)

(d) Remove sway bar brackets. (Fig 1-3)

(e) Remove the OE sway bar.

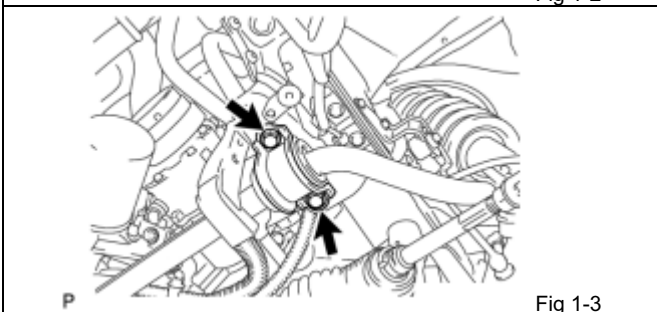
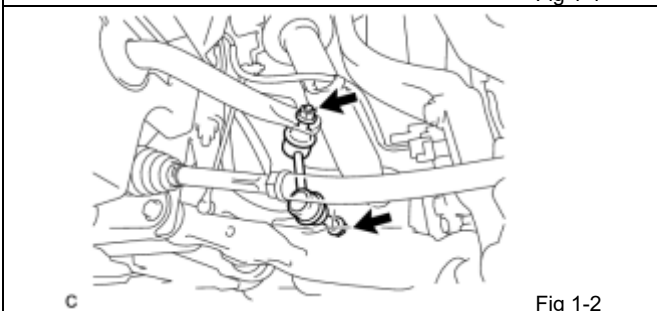
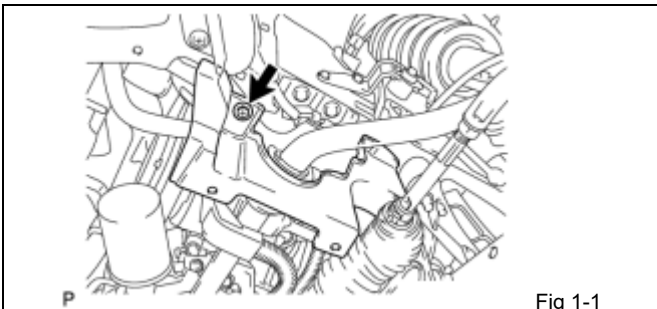

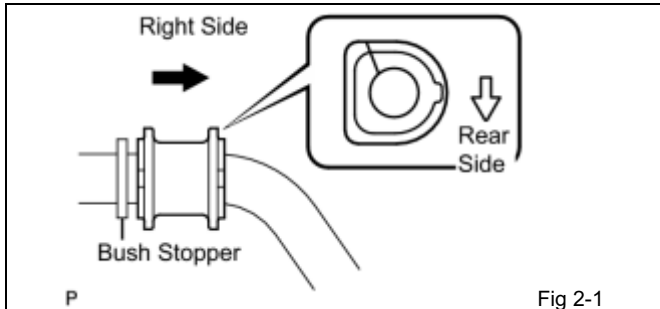

Fig 2-1

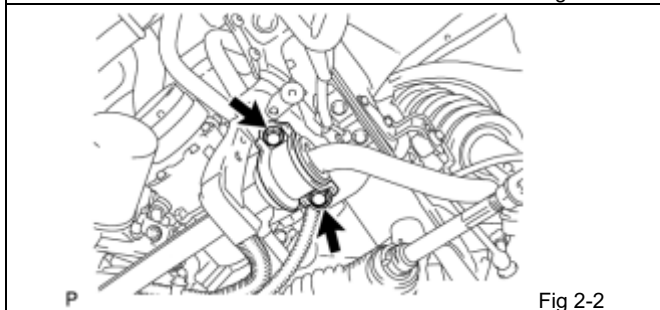

Fig 2-2

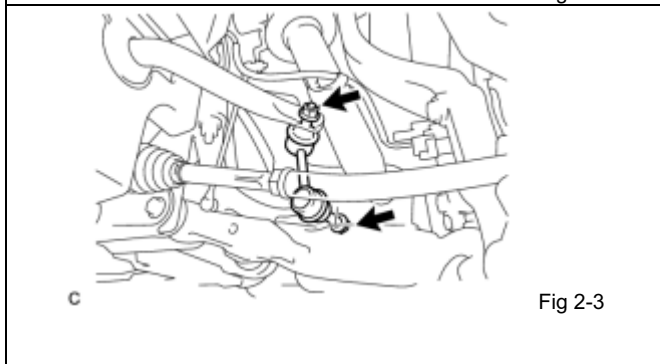

Fig 2-3

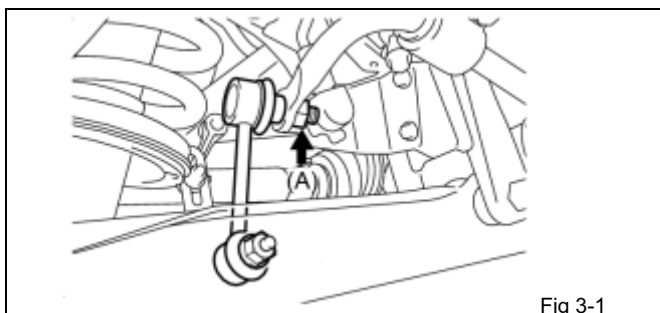

Fig 3-1

## 2. Install F-Sport Front Sway Bar

- (a) Install supplied bushings onto the new sway bar outboard of the locating rings.
  - (1) Cut in bushing should face the front of the vehicle. (Fig 2-1)

- (b) Hold sway bar in position and install the sway bar brackets. (Fig 2-2)

**Torque: 49 N·m (500 kgf·cm, 36 ft·lbf)**

- (c) Connect the sway bar links and tighten the nuts. (Fig 2-3)
  - (1) If the ball joint turns together with the nut, use a hexagon (6 mm) wrench to hold the stud.

**Torque: 84 N·m (856 kgf·cm, 62 ft·lbf)**

- (d) Install rear engine covers and main engine under cover.

## 3. Remove Rear Sway Bar.

- (a) Disconnect sway bar links. (Fig 3-1)

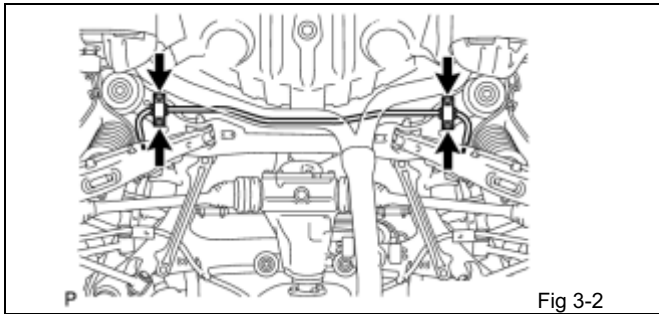

(b) Remove rear sway bar. (Fig 3-2)

- (1) Remove the 4 bolts and rear stabilizer bar with integrated brackets and discard.

**NOTE:** Some 2006 models may not have integrated brackets, installation is the same.

#### 4. Install F-Sport Rear Sway Bar.

(a) Install the supplied bushings onto the new rear sway bar.

- (1) Be sure to install the rear stabilizer bushing so that the cut in the bushing faces the rear of the vehicle. (Fig 4-1)

- (2) Bushings should be positioned to the very edges of the straight portion of the sway bar.

(b) Install the rear stabilizer bar with the supplied 4 bolts and sway bar straps. (Fig 4-2)

**Torque: 32 N·m (326 kgf·cm, 24 ft·lbf)**

**HINT:** Position link ends into the sway bar holes before bolting up the brackets.

(c) Tighten the sway bar links. (Fig 4-3)

- (1) If the ball joint turns together with the nut, use a hexagon (6 mm) wrench to hold the stud.

**Torque: 89 N·m (908 kgf·cm, 66 ft·lbf)**

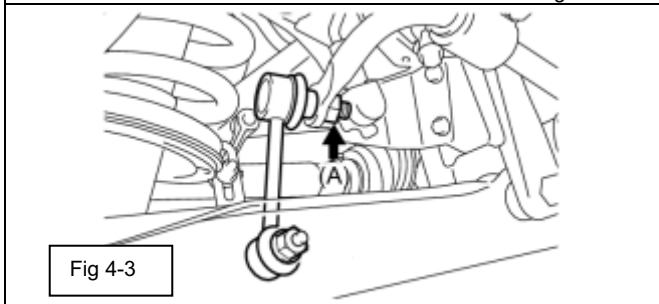
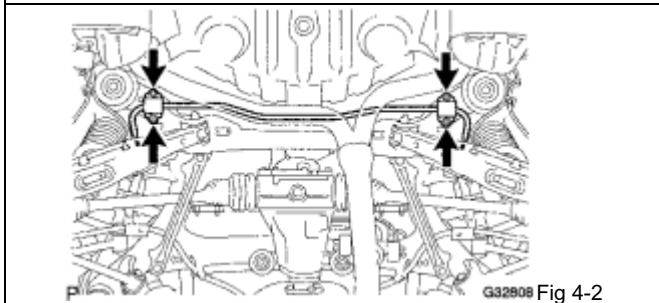
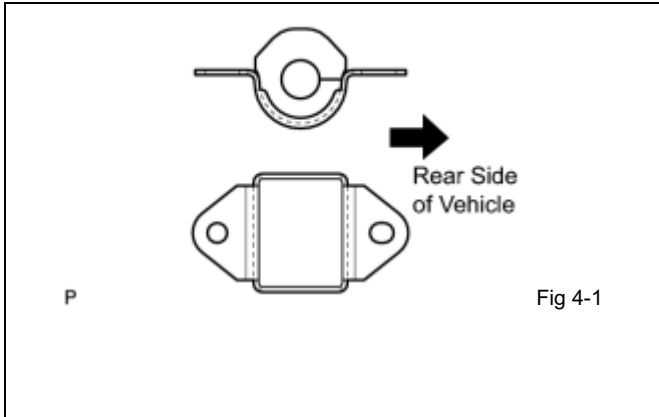

Checklist. These points MUST be checked to ensure a quality installation.

CHECK FOR:

Accessory Function Checks

LOOK FOR:

Vehicle Function Checks

Confirm all suspension components are tightened to specification.